

level measurement

level switch NGS 050

features

- level switch for fluid types
- aseptic measuring point by process connection thread M12 for modular welded sleeve- and process connection system
- EHEDG-conform, food safe material
- **starting an adjustment by PC not necessary**
- defined position of screwing

technical specifications

- connection head made of stainless steel 1.4305
- food tangent sensor made of PEEK
- process connection M12 modular system
- electrical connection with screwing or optional M12-plug
- protection class IP69K
- auxiliary supply 12...35VDC
- output signal active, max 50mA, short-circuit proof
- switching function full/empty by polarity of auxiliary supply
- temperature range 0...140°C process temperature for 30min
- high temperature design with neck tube optional
- temperature range connection head -20°C to +80°C
- max. operating pressure 10bar
- optional with switching status LED

application areas

- fill level detection in cases and pipelines from DN15
- dry running condition protection
- empty-/full announcement



NGS 050



M12-leak-proof system

**We make it „robust“!!
sealed electronic**

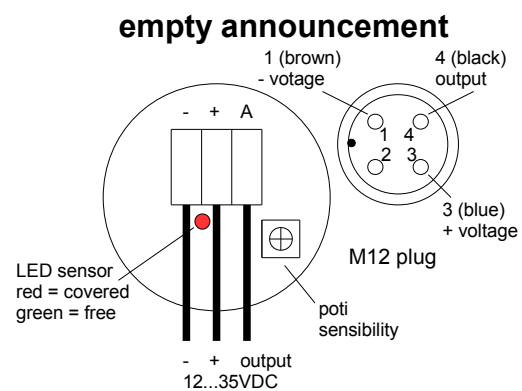
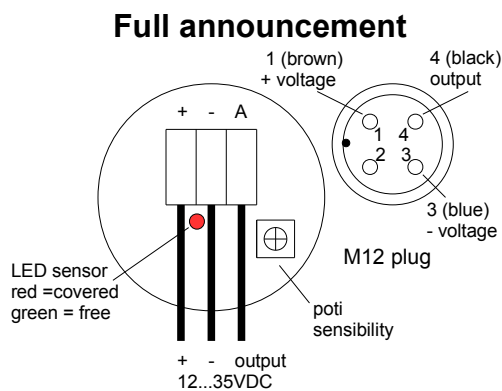

order-code NGS 050...

order example: NGS050-5-A-1

connection heads

- 5 stainless steel head standard with screwing
- 6 stainless steel head standard with M12-plug

design

- A standard design

optional

- 1 standard design
- 2 with extern switching status LED